

PhET Interactive Simulations

Effective classroom use

Michael Dubson

U. Colorado at Boulder

Physics Dept

NSF New Faculty Workshop, June 2013

What is PhET?

Originally, the Physics Education Technology project.

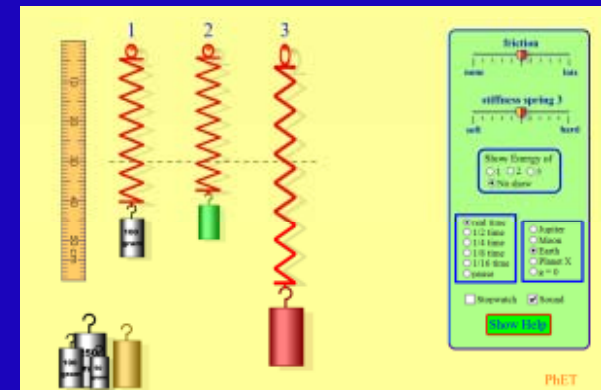
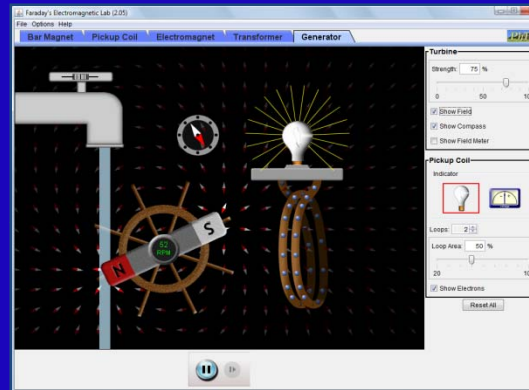
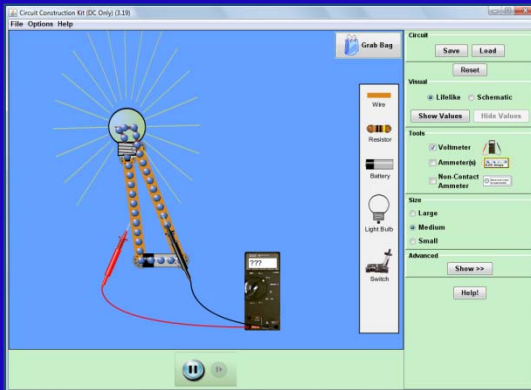

- Suite of **>100** interactive sims for science education.
- Research-based and user-tested.
- Java and Flash, run in browser or offline.
- Physics, Math, Chemistry, Earth Science, Biology.
- All FREE. Source code available.

Where is PhET?

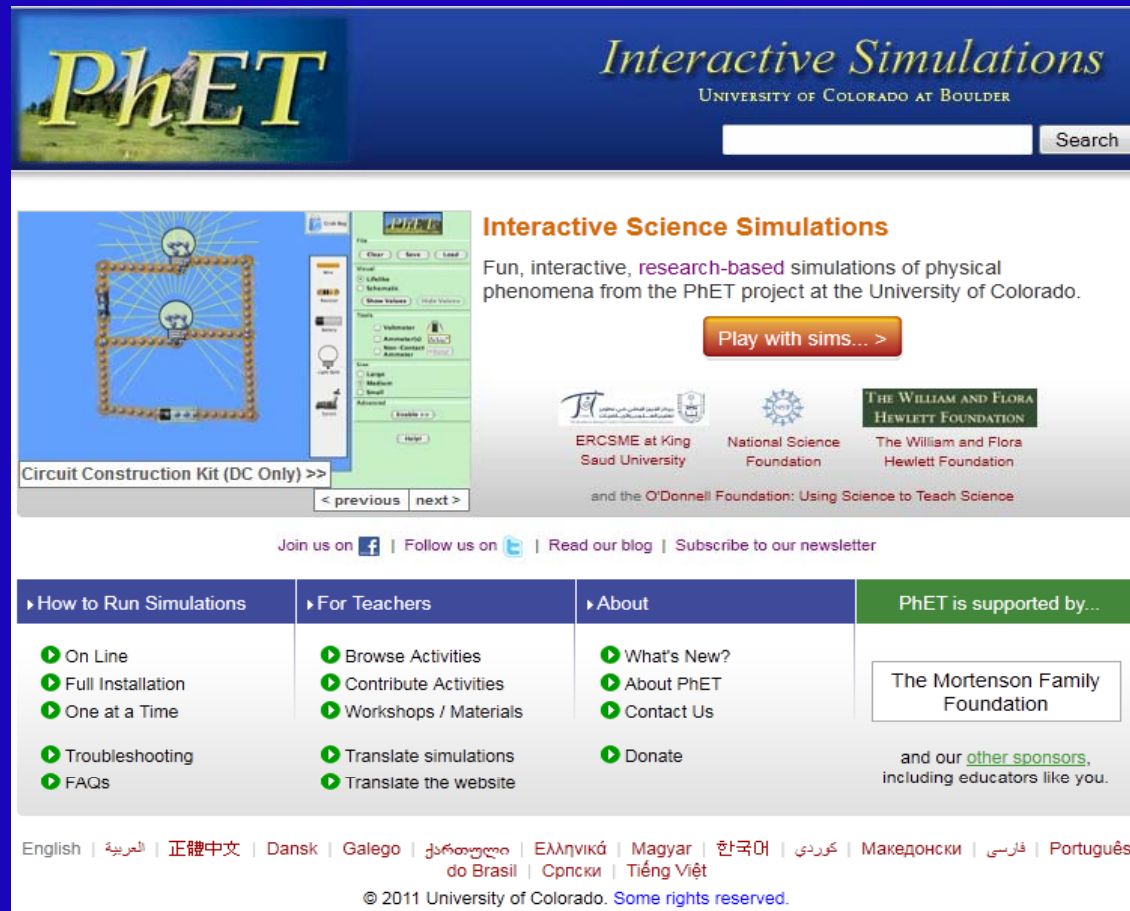

The screenshot shows the PhET website homepage. At the top left is the PhET logo. To the right, it says "Interactive Simulations" and "UNIVERSITY OF COLORADO AT BOULDER". Below this is a search bar. The main content area features a "Circuit Construction Kit (DC Only)" simulation interface on the left and a "Interactive Science Simulations" section on the right. The right section includes a description: "Fun, interactive, research-based simulations of physical phenomena from the PhET project at the University of Colorado." Below this is a "Play with sims..." button and logos for funding organizations: ERCSME at King Saud University, National Science Foundation, and The William and Flora Hewlett Foundation. At the bottom of the page, there are social media links (Facebook, Twitter, Blog, Newsletter) and a navigation menu with four columns: "How to Run Simulations", "For Teachers", "About", and "PhET is supported by...". The "PhET is supported by..." column lists "The Mortenson Family Foundation" and "our other sponsors, including educators like you." At the very bottom, there is a list of languages and a copyright notice: "© 2011 University of Colorado. Some rights reserved."

PhET *Interactive Simulations*
UNIVERSITY OF COLORADO AT BOULDER

Search

Interactive Science Simulations
Fun, interactive, research-based simulations of physical phenomena from the PhET project at the University of Colorado.

Play with sims... >

ERCsME at King Saud University | National Science Foundation | THE WILLIAM AND FLORA HEWLETT FOUNDATION

and the O'Donnell Foundation: Using Science to Teach Science

Join us on [f](#) | Follow us on [t](#) | Read our blog | Subscribe to our newsletter

How to Run Simulations	For Teachers	About	PhET is supported by...
<ul style="list-style-type: none">On LineFull InstallationOne at a TimeTroubleshootingFAQS	<ul style="list-style-type: none">Browse ActivitiesContribute ActivitiesWorkshops / MaterialsTranslate simulationsTranslate the website	<ul style="list-style-type: none">What's New?About PhETContact UsDonate	<p>The Mortenson Family Foundation</p> <p>and our other sponsors, including educators like you.</p>

English | العربية | 正體中文 | Dansk | Galego | ქართული | Ελληνικά | Magyar | 한국어 | كوردی | Македонски | فارسی | Português do Brasil | Српски | Tiếng Việt

© 2011 University of Colorado. Some rights reserved.

<http://phet.colorado.edu>

Examples:

- Circuit Construction kit.
- Masses and Springs.

Who is PhET?

Founded by Carl Wieman, 2002

Part of the Physics Education Research Group at CU Boulder



University faculty, post-docs,
K-12 teachers, software developers

Prof. Kathy Perkins, CEO, education researcher, and
grant-getter extraordinaire



Accessible

- Open-use License: Creative Commons - Attribution
- Easy to translate for World-wide Use:
Over 2700 translations in 59 languages,
34% of use outside US
- >40 million sims run last year, exponential growth

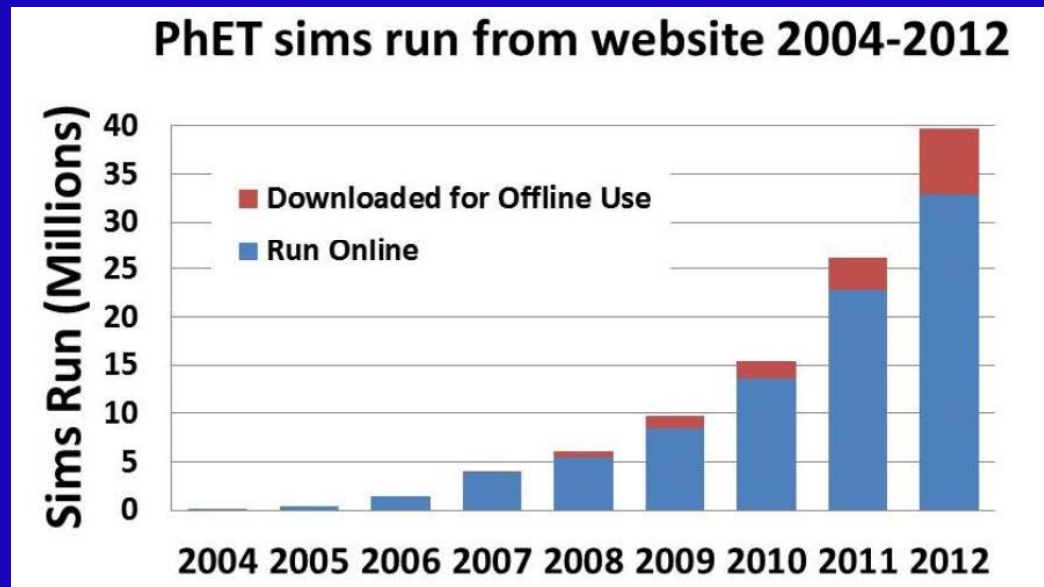

PhET around the world



Serbia



Brazil



Vietnam

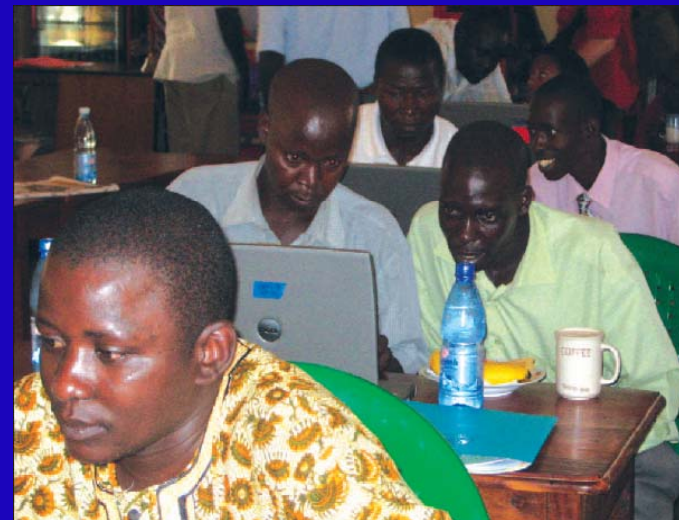

Uganda

What is PhET's intended audience?

- Originally, college freshmen, physics sims
- Now, grade school through grad school
sims are physics and math,
many chemistry, some earth science and biology

Arithmetic Workout

X	1	2	3	4	5	6	7	8	9
1									
2	2							16	
3		6							
4	4								
5						30		40	45
6									
7	7		21	28					
8									
9									36

7 × 7 = 49

Arithmetic Workout

Build an Atom

Build an Atom

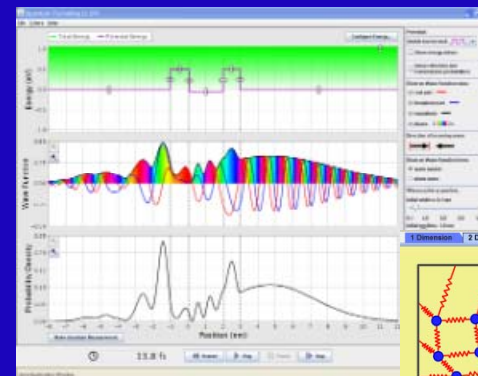

QM Tunneling

Normal Modes

Normal Modes

How might you use these sims
in your school?

Designed for versatile use

- Pre-lecture assignment
- Interactive Lecture Demonstration
- Clicker Questions
- In-class activity
- Lab or Recitation
- Homework

No silver bullet: context and activity critical

Versatile!

- Flexibility for you to
 - ✓ Pick and choose which sims to use
 - ✓ Customize use ...
to your environment and your learning goal
 - ✓ Search database of activities (>500 by PhET or Teacher-users)

Circuit Construction Kit

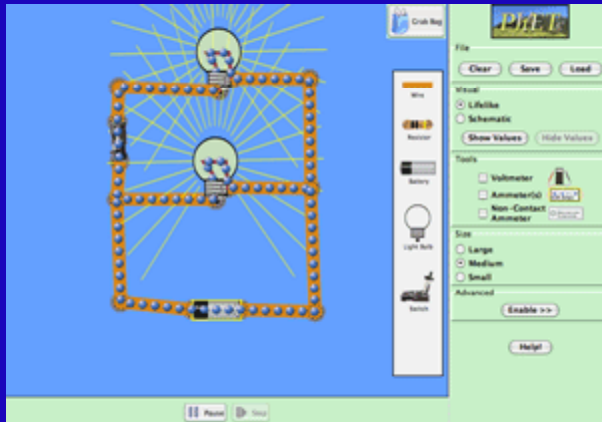

CCK in grade school:

“Make the light bulb light”

CCK in college:

“Explain why the light dims when you turn the heater on”

Examples:

- Friction
- Energy Skate Park

Example: Concept Tests

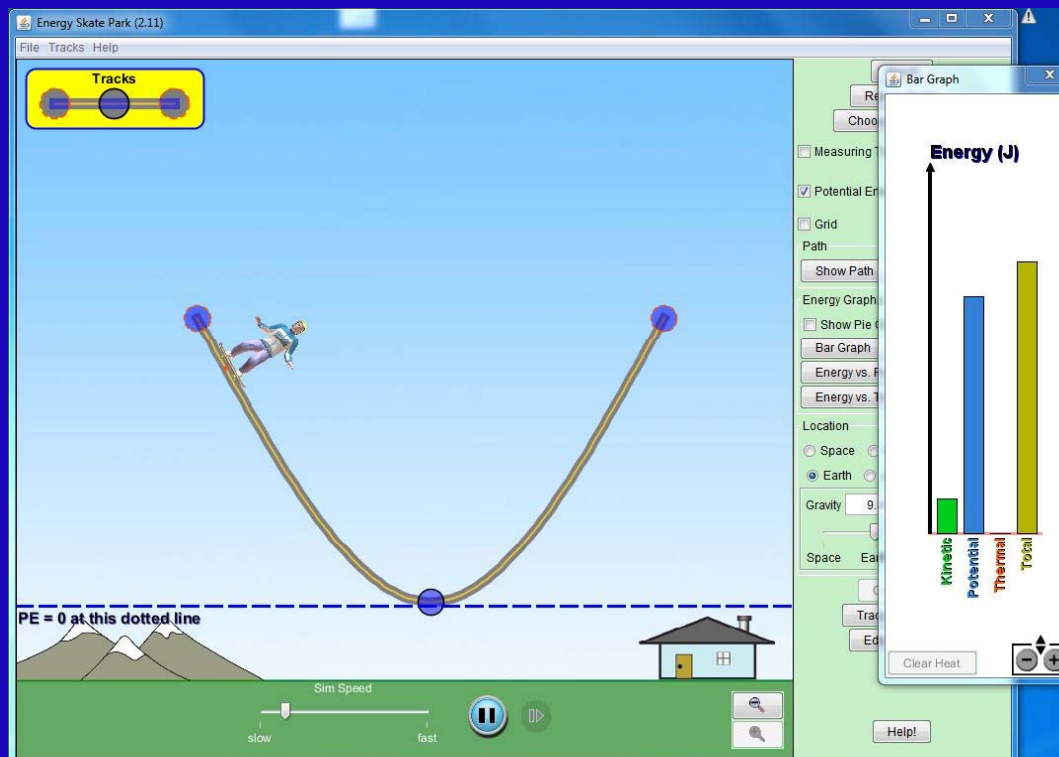

I move the zero of PE up to the starting point of the Skateboarder (skateboarder still starts from rest).

The total energy of the system is now:

- A) Zero
- B) positive
- C) negative
- D) Depends on the position of the skateboarder

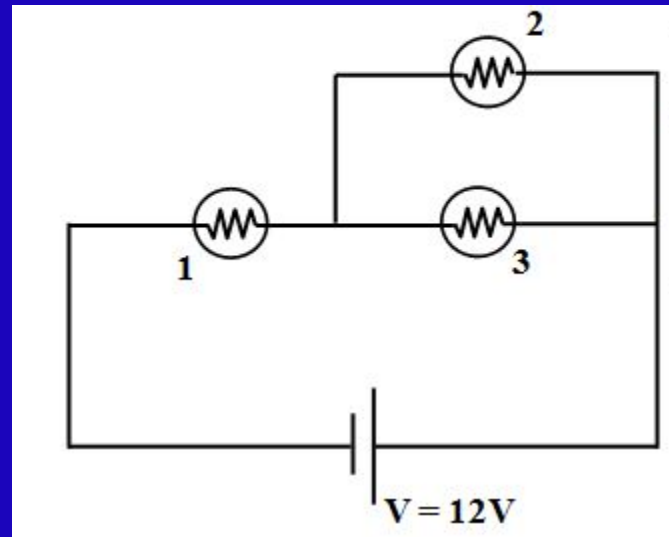

In the circuit, what happens to the brightness of bulb 1, when bulb 2 burns out? (When a bulb burns out, its resistance becomes infinite.)

- A) Bulb 1 gets brighter
- B) Bulb 1 gets dimmer.
- C) Its brightness remains the same.

(Hint: What happens to the current from the battery when bulb 2 burns out.)

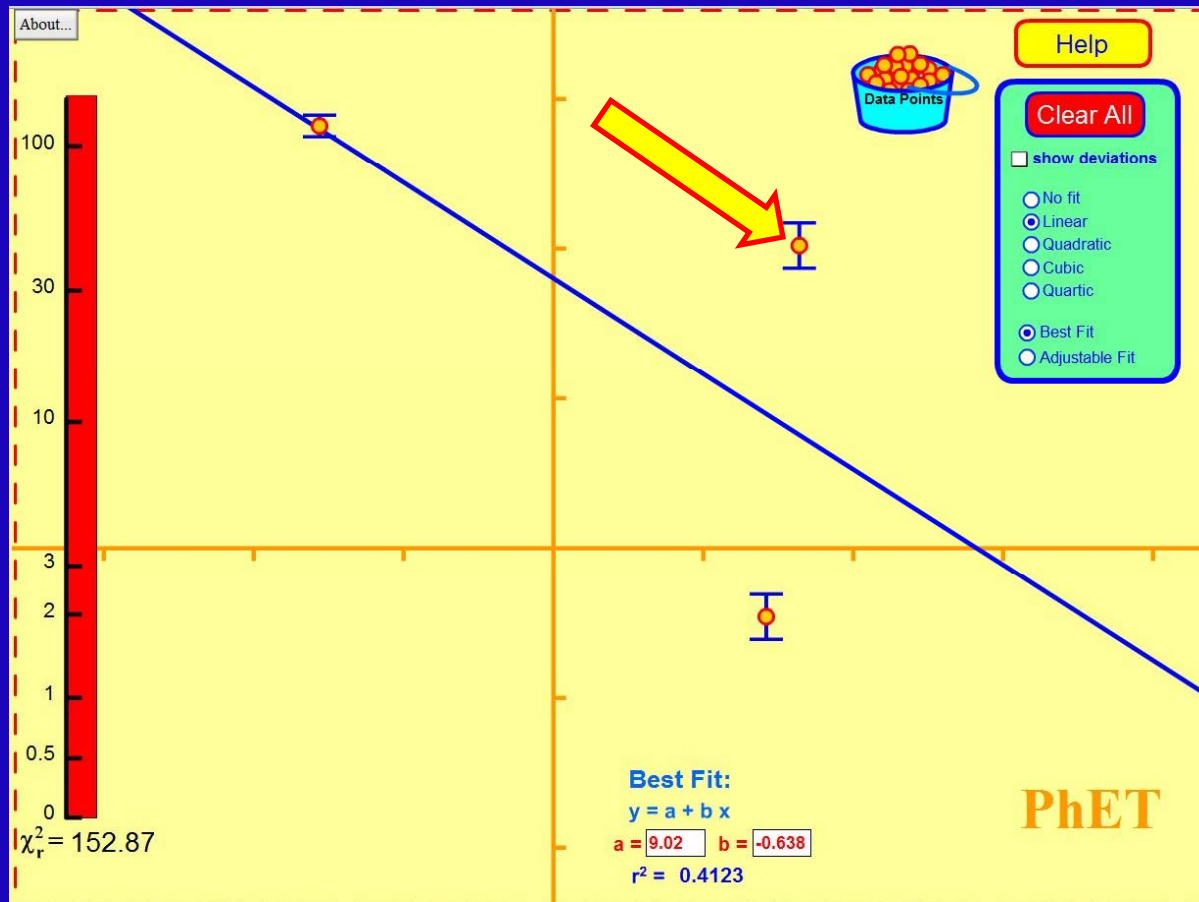

If we increase the error bar on the data point shown, what happens to the slope of the best-fit line?

- A) It becomes more negative (line tilts CW).
- B) It becomes less negative (line tilts CCW).
- C) It does not change.

Why is PhET successful?

- Diverse design team
- User interviews
- Classroom testing
- Research-based



Design Philosophy

- Inviting, intuitive interface, usable without instructions
- Highly interactive: instant animated feedback as students explore
- Accurate, dynamic visual representations; show the invisible
- Allow actions that would be difficult or impossible in the real world
- Game-like environment
- Interface design that implicitly scaffolds inquiry

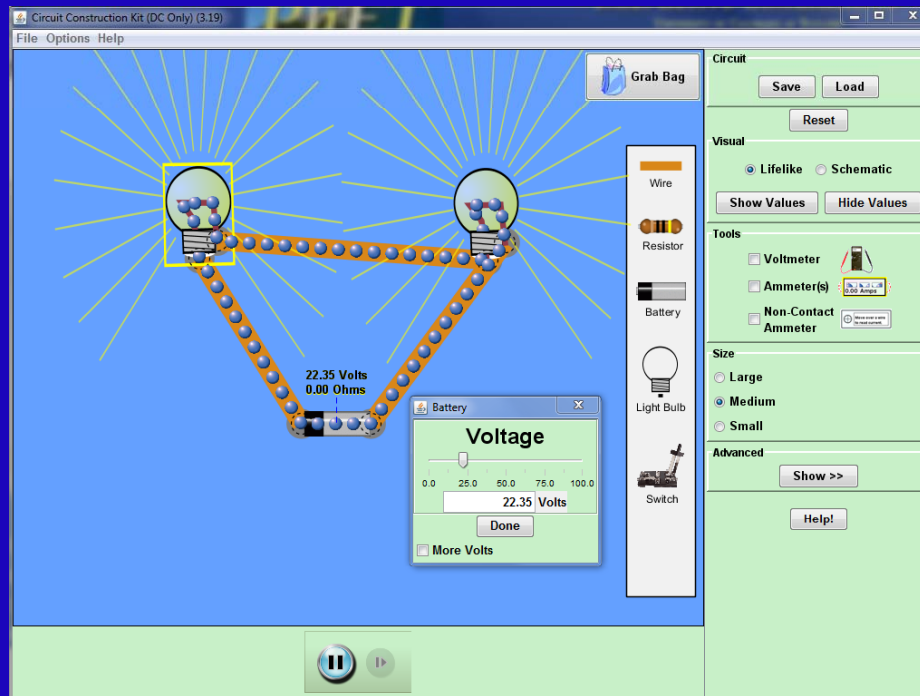

Research-Based Design supports inquiry-learning

Use accurate, dynamic visual representations

Show the invisible

Create a game-like environment

Make simulations highly interactive

Provide real-time, animated feedback as students play

Implicitly scaffold inquiry through design of controls and representations

Allow actions that would be difficult or impossible in the real world

Provide an intuitive interface, usable without instructions

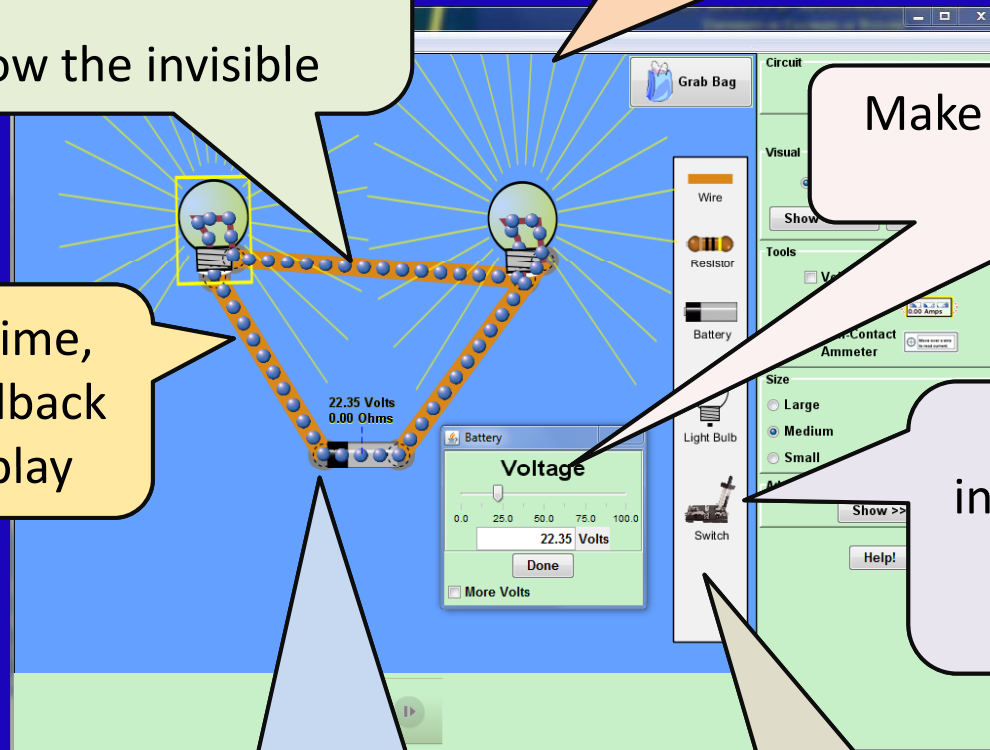

PhET Design Process

2 – 12 months, ≈\$50K/sim

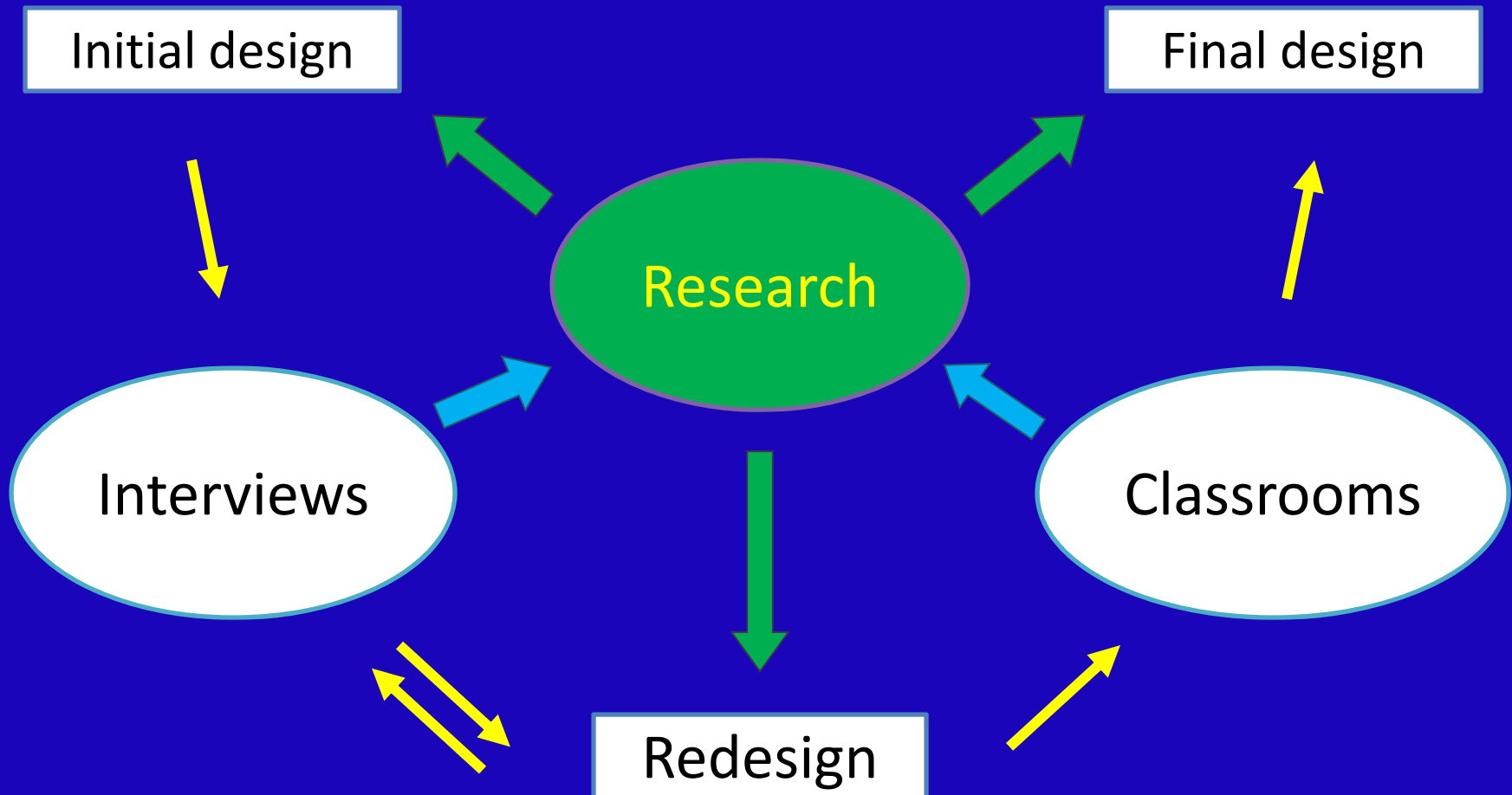

Compare these tools:

Your thoughts...

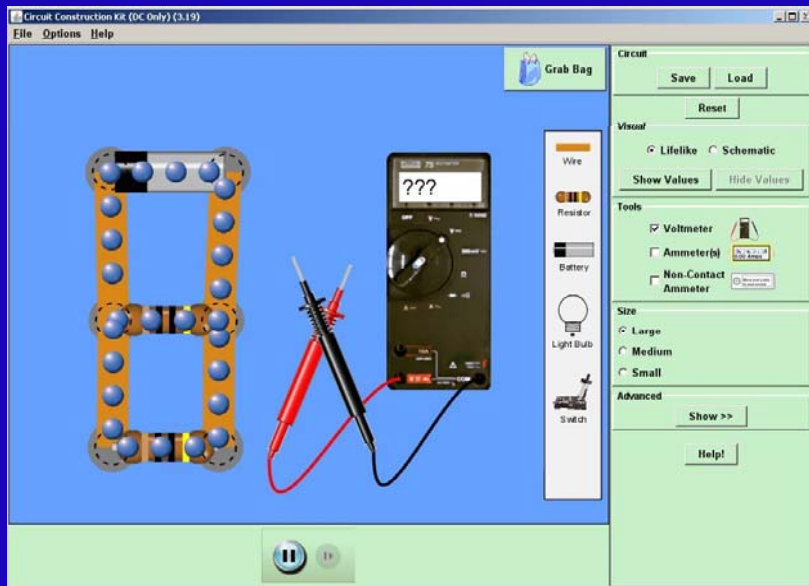

PhET in popular culture

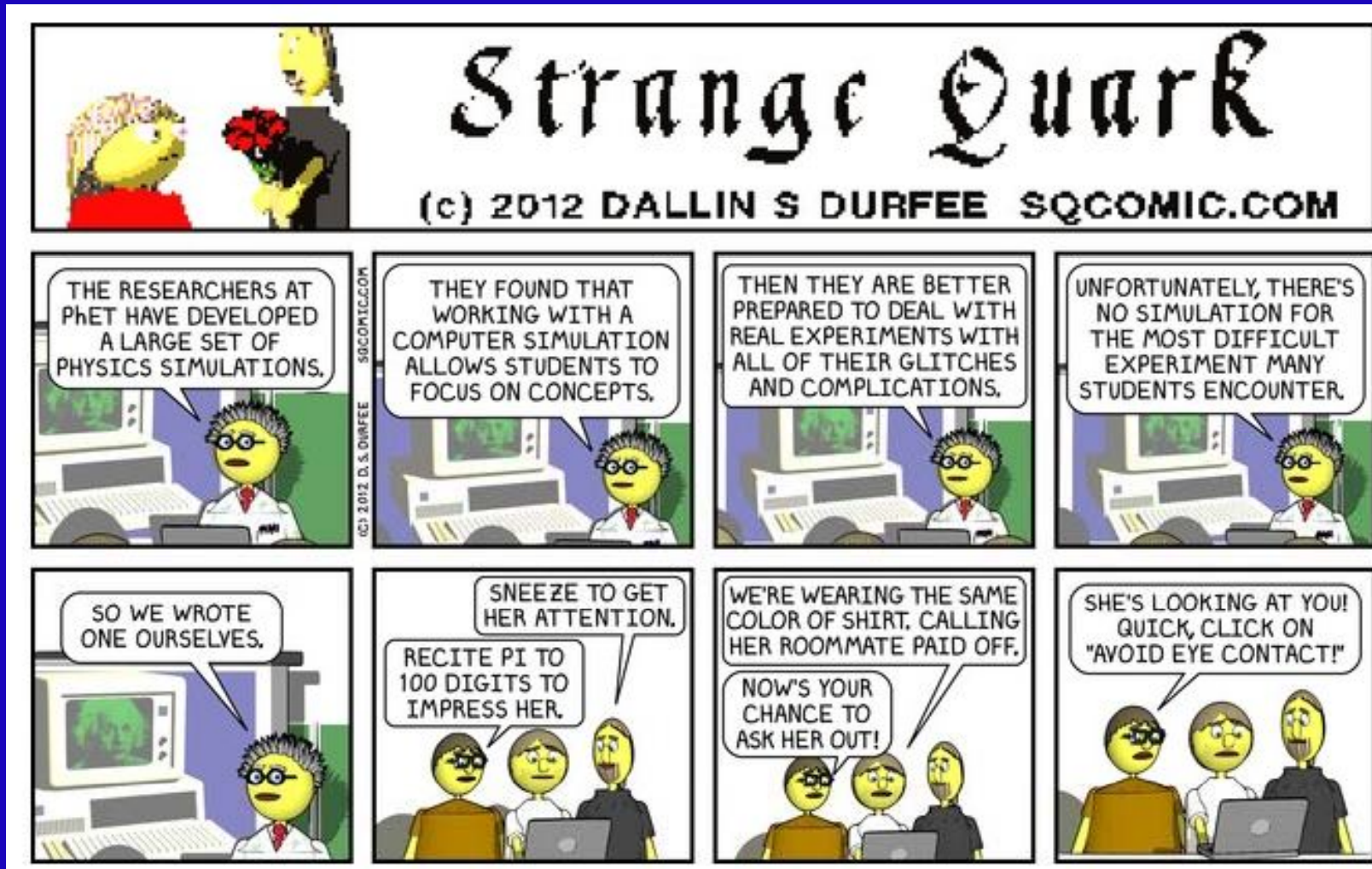

Can PhET sims replace real equipment?

- They can, but we don't think they should.
- Meant to compliment, not replace with lab equipment.
- Sims lack real-world “dirt” effects, allow students to focus on physics concepts.

Circuit Construction Kit vs. real circuits

“When learning about the real world is better done virtually..”, N.D. Finkelstein et al., **Phys. Rev. ST Phys. Educ. Res.** 1, 010103, 2005.

Students who only used virtual circuits, did equally well on building real circuits final.

Sims allow risk-free, rapid inquiry cycle.

Questions 1, 2, and 3 refer to the circuit below in which four identical light bulbs are connected to a battery. The switch S is initially closed (conducting) as shown.

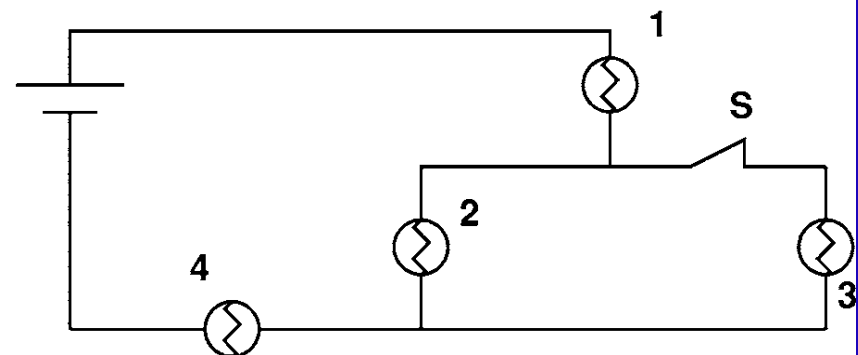

Do students learn if I just tell them to play with a sim?

- Seldom. Guided inquiry essential.
- Large data-base of classroom-tested activities available on the PhET site.

What makes a good sim activity?

- *Minimum* instruction.
 - Detailed procedures *inhibit* student exploration.
- Clear Learning Goals
 - Give students the *goal*, not the procedure.

In-Class activity or Lab

Worse:

- Give directions on how to use the sim

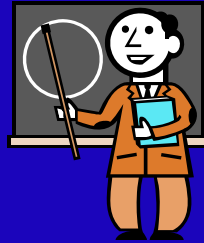

- Result: Students are nervous, reluctant to try things, ask lots of questions about sim use, not learning goals.

Better:

- Provide activity and do not offer any pointers on the sim itself

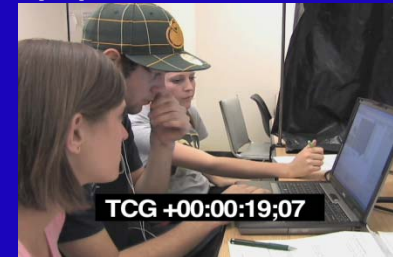

- Result: Students explore uninhibitedly, quickly find/learn all the controls, become the "owner" of the sim.

Example Activity: Masses and Springs

- 5-10 minutes of play – No instructions.
- Challenge 1: Using data from the sim, make a graph that shows whether or not the springs obey Hooke's Law.
- Challenge 2: What is the mass of the red weight?
- Challenge 3: Determine the spring constant in two different ways: with your graph from (1) and with the stopwatch.

Cookbook directions (NOT effective):

- Watch me while I show you the controls.
- Measure the equilibrium extension of spring 1, for each of the 3 different known masses, and make a graph of stretch of the spring (on y-axis) vs. mass (on x-axis). From this, determine the spring constant k of the spring. Recall that $F_{\text{spring}} = -kx$, where x is the stretch of the spring. Don't forget that weight is mg , where $g = 9.8 \text{ m/s}^2$.

What would you like to see in PhET?

- Sim ideas? New features? ??

Door Prize! : You can see NEW sims in development, before they are published, at

<http://www.colorad.edu/physics/phet/dev>

The Future...

- More sims
- Compatibility with iPad
- Classroom sim sharing

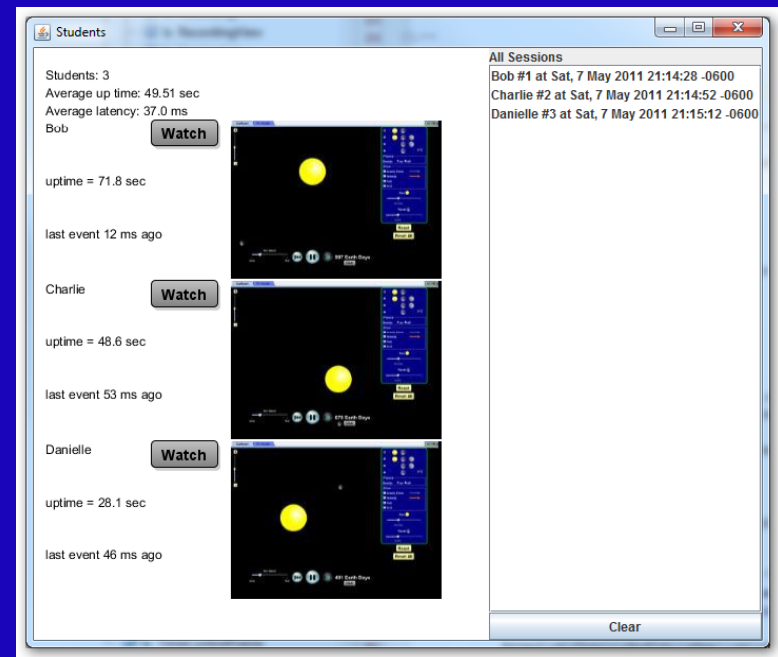

How can you contribute?

For Teachers > **Submit an Activity**

Send us your ideas
for new sims!

Report bugs

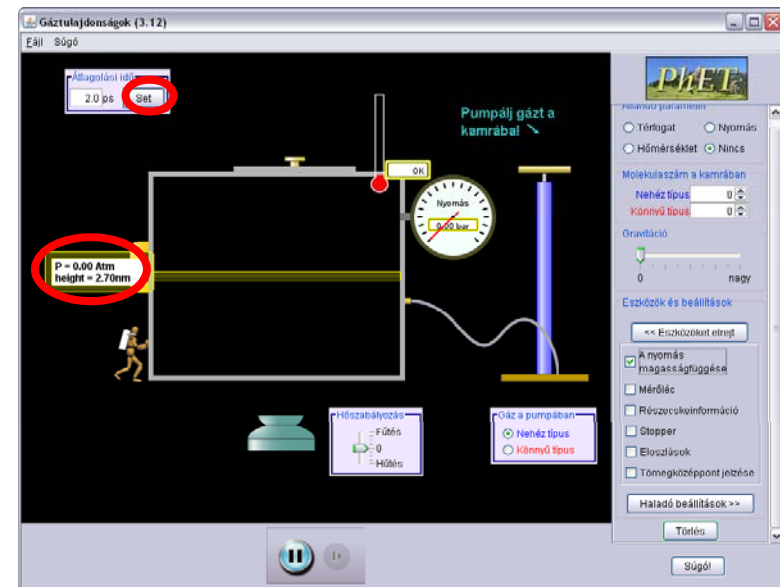

Email: phethelp@colorado.edu

How can PhET be *free*?

Current budget > \$1M / year



NSF

THE WILLIAM AND FLORA HEWLETT FOUNDATION

Hewlett Foundation

The O'Donnell Foundation



King Saud University



University of Colorado



Carl Wieman & Sarah Gilbert

How can PhET *stay* free?

- We're not sure.
- Major funding from grants not sustainable.
- Seeking corporate sponsors, large and small donors.
- Your advise or \$\$ gratefully accepted.



PhET Interactive Simulations

- Suite of >100 interactive simulations
- Physics , Chemistry , Math
Expanding into biology, earth science
- Research-based and user-tested
- **Free!** Online or downloadable. (~130 MB)
- Easy to use and incorporate in class

<http://phet.colorado.edu>

Extra Slides Follow

Designing Activities: What do students learn in each activity?

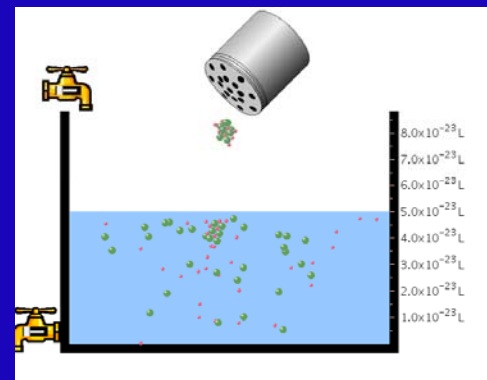

Add 100 silver bromide pairs to the water. How many silver and bromide ions dissolve in the water? Repeat this for all salts.

Investigate different salts. What features do salts have in common, and how do salts differ from each other?

Old Acid-Base Solutions

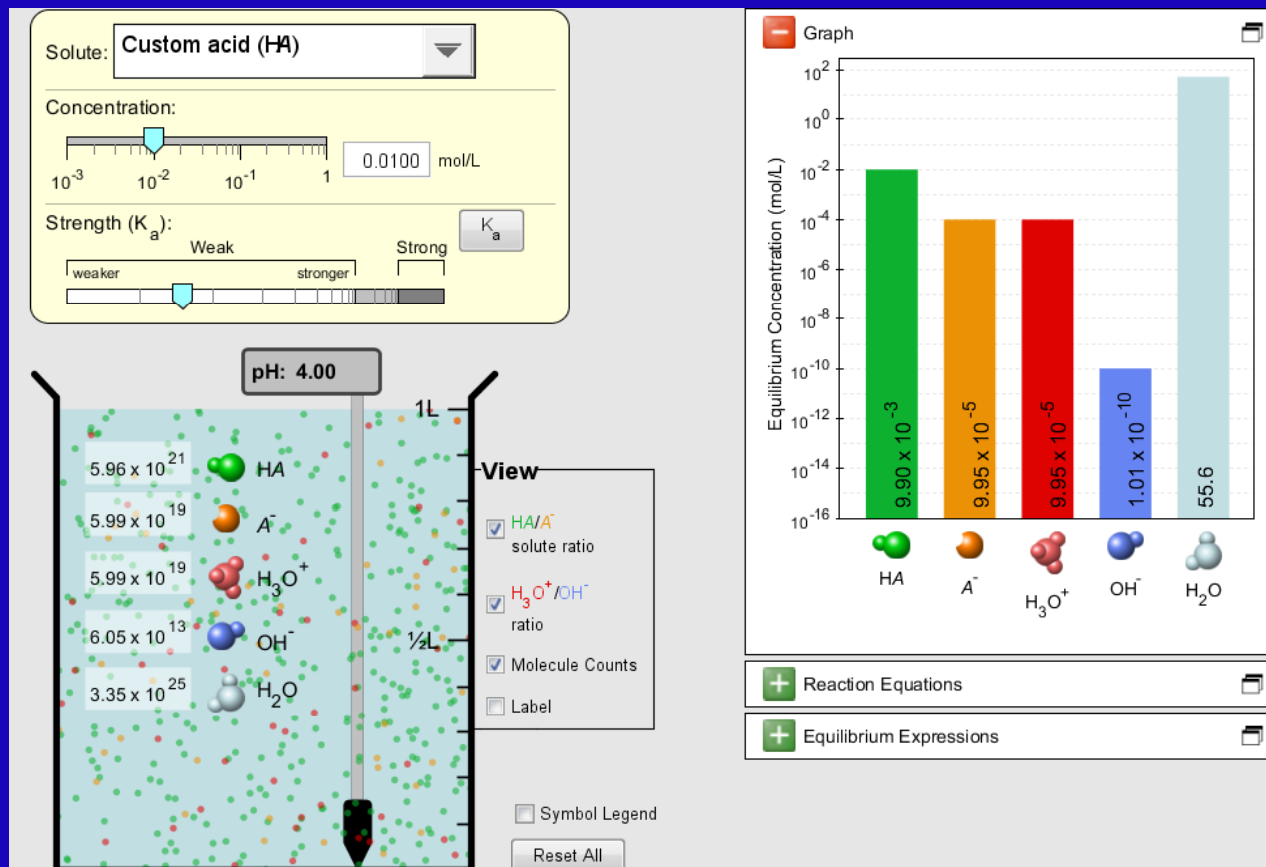

New Acid-Base Solutions

Acid-Base Solutions (1.00)

File Help

Introduction Custom Solution

pH Color Key

0 1 2 3 4 5 6 7 8 9 10 11 12 13 14

1L

HA + H₂O → A⁻ + H₃O⁺

Solutions

- Water (H₂O)
- Strong Acid (HA)
- Weak Acid (HA)
- Strong Base (MOH)
- Weak Base (B)

Views

- Molecules
- Show Solvent
- Equilibrium Concentration
- Liquid

Tests

- pH Meter
- pH Paper
- Conductivity

Reset All

Why is this sim better?

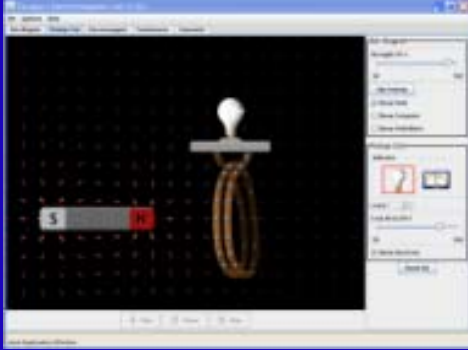

Interview Study: Type of Guidance

Compared two types of guidance
Examined Student Behavior

Open Conceptual
Questions +

Guided Activity

*In the "Bar Magnet" tab,
identify all controls, ...
What does the
"Strength" slider do?*

Open Conceptual
Questions



Free exploration
of sim

Results

Guided Activity

Student Mode:

Students answer question
and wait for the next.

“OK, continue?”

“Is that sufficient for step 2?”

Often don't tie pieces
together.

Open Conceptual Questions

Scientist-like Exploration:

Explore via their own
questioning

“Oh, I wasn't expecting that”

*“I was looking around to see
if it was an effect of having
more wires.”*

What did students explore?

12 features not mentioned in the Cookbook activity:

