

# PHYSICSBOWL 2021

March 24 – April 9, 2021

40 QUESTIONS – 45 MINUTES

The 2021 PhysicsBowl, organized by the **American Association of Physics Teachers**, is an opportunity to recognize outstanding high school physics students and their teachers through their performance on this year's contest.

- Schools compete in one of two divisions, each with nineteen regions.
  - *Division 1* is for students *taking physics for the first time* (even if that first course is AP Physics).
  - *Division 2* is for students taking a second (or more) course in physics OR anyone wanting a challenge.
- A school's team score in each division is the sum of the five highest student scores in that division.
- A school may compete in either or both divisions.

## INSTRUCTIONS

**NOTE:** There will be no paper copies and bubble sheets for the 2021 exam.

**WebAssign:** All 2021 exams will be taken electronically via *WebAssign*. Your exam proctor will provide you with the necessary link and code to access the exam.

**Questions:** The test is composed of 50 questions; however, students answer only 40 questions.

**Division 1 students will answer only questions 1 – 40.** Do not answer questions 41 – 50.

**Division 2 students will answer only questions 11 – 50.** Do not answer questions 1 – 10.

**Calculator:** A hand-held calculator may be used. Any memory must be cleared of data and programs. Calculators may not be shared.

**Formulas and constants:** Only the formulas and constants provided with the contest may be used.

**Time limit:** 45 minutes.

**Score:** Your score is equal to the number of correct answers (no deduction for incorrect answers). If there are tie scores, the entries will be compared from the end of the test forward until the tie is resolved. Thus, the answers to the last few questions may be important in determining the winner and you should consider them carefully.

**Good Luck!**

Copyright © 2021, AAPT

**DIVISION 1  
STUDENTS**

**START HERE.**

**DIVISION 2  
STUDENTS**

Go to question #11  
on page 4.

**Treat  $g = 10.0 \frac{m}{s^2}$  for ALL questions.**

1. The Joule (J) is a derived unit of energy in the International System of Units. It is equal to which of the following

A)  $kg(\frac{m}{s})$       B)  $kg(\frac{m}{s^2})$       C)  $kg(\frac{m^2}{s})$       D)  $kg(\frac{m^2}{s^2})$       E)  $kg(\frac{m^2}{s^3})$

2. A force,  $F$ , could be applied to a cart in a variety of directions as shown at right. Which of the applications of  $F$  would result in no work being done?

A) A  
B) B  
C) C  
D) D  
E) All of them result in work being done.

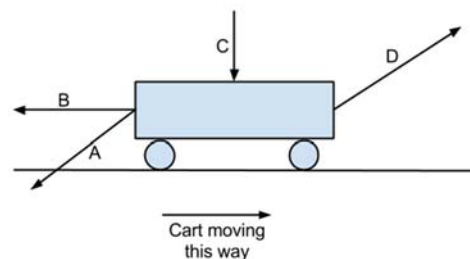

3. A brick is moving at a speed of 3 m/s and a pebble is moving at a speed of 5 m/s. If both objects have the same kinetic energy, what is the ratio of the brick's mass to the pebble's mass?

A) 25:9      B) 5:3      C) 4:1      D) 3:1      E)  $\sqrt{5}:\sqrt{3}$

4. The figure to the right shows the position-time graph of an object traveling in a straight line, starting out moving to the right (the positive x-direction). At which points is the object moving to the left?

A) B and F  
B) E and F  
C) A, B, and C  
D) C, D, and E  
E) None of the above

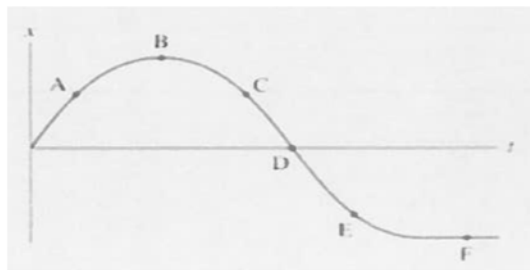

5. A hole with a radius of 1.0 mm develops in the bottom of a 15 m tall tank filled to the top with water. The tank is open at the top. At what rate will water initially flow out of the hole?

A)  $5.4 \times 10^{-3} \text{ m}^3/\text{s}$   
B)  $5.4 \times 10^{-4} \text{ m}^3/\text{s}$   
C)  $5.4 \times 10^{-5} \text{ m}^3/\text{s}$   
D)  $5.4 \times 10^{-6} \text{ m}^3/\text{s}$   
E)  $5.4 \times 10^{-7} \text{ m}^3/\text{s}$

6. Which of the following scientists was awarded a Nobel Prize in Physics in 1956 and again in 1972?

A) John Bardeen      B) Enrico Fermi      C) Murray Gell-Mann  
D) Hans Bethe      E) Wolfgang Pauli

7. Two cranes are used to lift loads vertically at constant speed from the ground to the top of a building. Crane 1 lifts an 8000-N load a height of 40 m in a time of 20 minutes. Crane 2 lifts a 6400-N load a height of 50 m in a time of 16 minutes. Which statement below correctly compares the mechanical power output of each crane?
- A) The cranes have the same power because they perform the same amount of work.
  - B) The cranes have the same power because the ratio of force exerted to time is the same.
  - C) Crane 1 has a greater power because it exerts more force to lift the load.
  - D) Crane 1 has a greater power because it raises the load over a longer time.
  - E) Crane 2 has a greater power because it performs the same amount of work in less time.
8. An ice skater is rotating with her arms extended. When she pulls in her arms, her rate of rotation increases. No external torques act on the skater. Which of the following statements is true?
- A) Her moment of inertia increased.
  - B) Her kinetic energy is conserved.
  - C) Her angular momentum decreased.
  - D) She does work when pulling in her arms.
  - E) Her angular momentum increased.
9. A rock that has a mass of 12 kg is sliding on a rough, horizontal surface. It has 24 J of kinetic energy and the friction force on it is a constant 0.50 N. What distance will it slide before coming to rest?
- A) 2.0 m                      B) 12 m                      C) 24 m                      D) 36m                      E) 48 m
10. The average density of blood is  $1.06 \times 10^3 \text{ kg/m}^3$ . Imagine that you donate a pint of blood during a local blood drive. What mass of blood, in grams, have you donated? (1 pt = 1/2 L, 1 L = 1000 cm<sup>3</sup>.)
- A) 530 g                      B) 0.530 g                      C) 5300 g                      D)  $5.30 \times 10^5$  g                      E) 53.0 g

**DIVISION 1  
STUDENTS**

**Continue**  
Answer questions #11  
through #40.

**DIVISION 2 STUDENTS**

**START HERE**  
Numbers 1 – 10 on your answer sheet  
should be blank. Your first answer  
should be for #11.

**Treat  $g = 10.0 \frac{m}{s^2}$  for ALL questions.**

11. An object of mass  $m$  initially at rest experiences a uniform, non-zero acceleration. Which of the following statements is correct?
- A) The object's displacement is directly proportional to its time of travel.
  - B) The object's velocity is directly proportional to its time of travel.
  - C) The object's acceleration is directly proportional to its time of travel.
  - D) The object's kinetic energy is directly proportional to its time of travel.
  - E) The net force acting on the object is directly proportional to its time of travel.
12. A person places some water on their fingertip and rubs the fingertip around the top surface of a water glass to produce a particular musical tone. This process is most closely associated with which of the following phenomena?
- A) Diffraction    B) Dispersion    C) Doppler effect    D) Refraction    E) Resonance
13. An object is placed 20 cm in front of a converging lens with a focal length of 30 cm. What is the distance between the object and its image?
- A) 8 cm    B) 32 cm    C) 40 cm    D) 60 cm    E) 80 cm
14. A person standing 5.0 m from a barking dog measures the sound intensity level to be 65 dB. What would be the intensity level at that same distance if two identical dogs very close to each other are barking?
- A) 34 dB    B) 65 dB    C) 68 dB    D) 130 dB    E) 136 dB
15. In the Millikan oil-drop experiment the UPWARD force on a stationary oil drop is due to the:
- A) gravitational and electric fields
  - B) gravitational field and the charge on the drop
  - C) electric field only
  - D) electric field and the charge on the drop
  - E) charge on the drop only
16. A uniform wooden block is a rectangular prism with dimensions of 10 cm x 6 cm x 2 cm. The block will be placed on a level table in one of three possible orientations with a side parallel to the tabletop. Let  $P_L$  equal the largest possible pressure the block can exert on the table and  $P_S$  equal the smallest possible pressure the block can exert on the table. What is the ratio  $P_L/P_S$ ?
- A) 5/3    B) 3    C) 5    D) 9    E) 25

17. Several samples of different ideal gases all have the same temperature. Which of the following graphs could show the relationship between the atomic mass of the gas and the rms speed of the gas atoms?

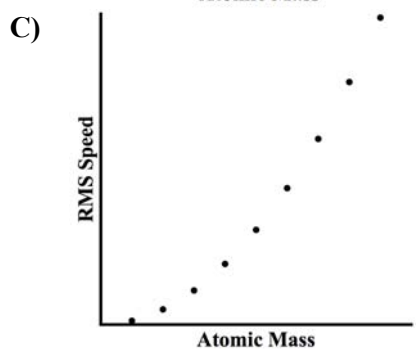
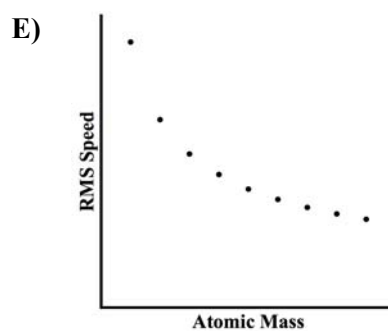
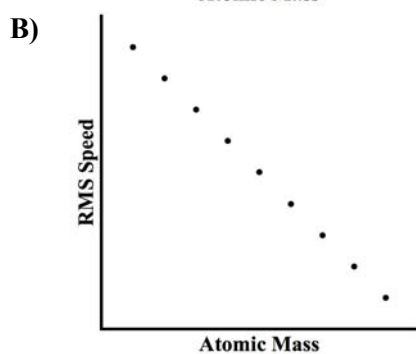
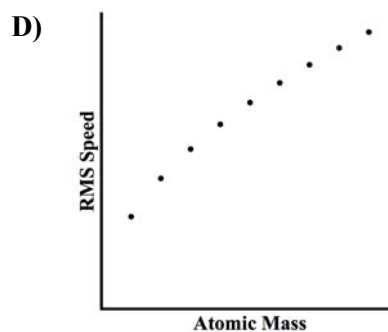
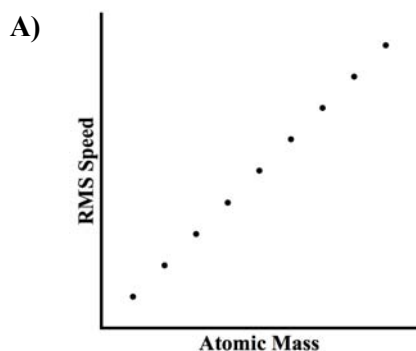

18. Two separate simple pendulums are swinging back and forth. It is found that pendulum A has twice the frequency of pendulum B. Which statement could account for this difference?
- A) Pendulum B is twice as long as pendulum A.
  - B) Pendulum B was released before pendulum A.
  - C) Pendulum B is twice as massive as pendulum A.
  - D) The length of pendulum B is four times the length of pendulum A.
  - E) The mass of pendulum B is four times the mass of pendulum A.

19. At  $t=0$ , Ball 1 is rolling up a ramp and Ball 2 is released from the top of the same ramp. The balls don't collide. Which velocity vs. time graph at right best represents the motion of the two balls?

- A) A  
 B) B  
 C) C  
 D) D  
 E) Both A & D

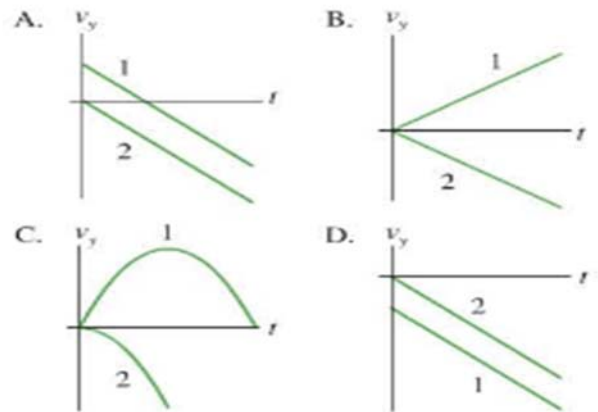

20. A simple and correct way to comprehend satellites orbiting Earth is to view them as

- A) balanced between gravitational and centripetal forces.  
 B) beyond the main pull of Earth's gravity.  
 C) in mechanical equilibrium with a net force of zero.  
 D) having sufficient tangential velocities to fall around rather than into Earth.  
 E) All of the above.

21. Two balloons are charged identically and uniformly by rubbing them with wool. One is placed on a scale which is then tared. No charge is transferred to the scale. The other is then placed above it separated by 30 cm. The scale reads 0.32 grams. What is the closest estimate for the charge on each balloon?

- A) 200 C  
 B) 200 mC  
 C) 200  $\mu$ C  
 D) 200 nC  
 E) 200 pC

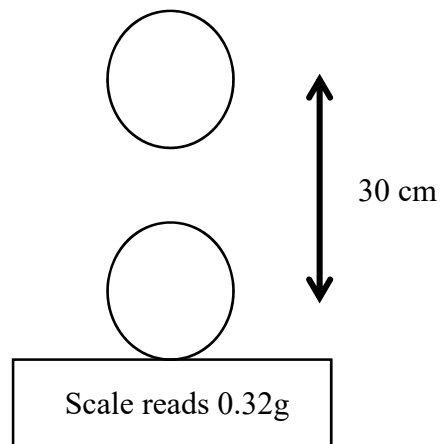

22. A fighter jet pilot is capable of tolerating an upward force that is equivalent to seven times their weight. This pilot is traveling at a speed of 250 m/s while pulling out of a vertical dive. What is the minimum radius of curvature of the plane's dive path?

- A) 4.25 m      B) 3.64 m      C) 1042 m      D) 893 m      E) 450 m

23. The mass of Mars is  $6.40 \times 10^{23}$  kg. Its radius is 3395 km. What is the mean density of Mars in  $\text{kg/m}^3$ ?

- A)  $9.76 \times 10^2$       B)  $1.95 \times 10^3$       C)  $3.90 \times 10^3$       D)  $7.81 \times 10^3$       E)  $7.94 \times 10^4$

24. In a panic, you squeeze the brake handle on your bicycle, lock up the rear wheel, and skid a certain distance on a straight, level path before stopping. If you had been traveling twice as fast, what distance would you have skidded, under the same conditions?
- A) You would have skidded 4 times farther.  
 B) You would have skidded twice as far.  
 C) You would have skidded 1.4 times farther.  
 D) You would have skidded 8 times farther.  
 E) It is impossible to tell from the information given.

**Questions 25 & 26 refer to the following information:**

Two balls, A and B, are launched simultaneously from the origin (O) on a level surface at the respective angles of  $60^\circ$  and  $30^\circ$  shown in the picture. Ball A has a launch speed  $v$  while Ball B has a launch speed  $2v$ . Ball A lands  $T$  seconds after launch at a horizontal distance  $D$  from the origin.

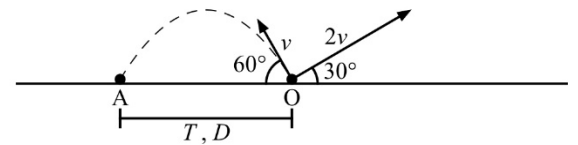

25. How many seconds after launch does Ball B land?  
 A)  $0.50T$       B)  $0.87T$       C)  $1.15T$       D)  $1.73T$       E)  $2.00T$
26. What horizontal distance separates the landing points of Ball A and Ball B?  
 A)  $2D$       B)  $3D$       C)  $4D$       D)  $5D$       E)  $6D$
27. You are given three 6-ohm resistors. Neglecting the resistance of any connecting wires, which of the following resistances CANNOT be made using one or more of these resistors?  
 A) 2 ohms      B) 3 ohms      C) 9 ohms      D) 12 ohms      E) 15 ohms
28. Electric energy can be generated in many ways, two of which are with nuclear plants using nuclear fission reactions, or coal fired plants utilizing chemical reactions. Energy density for a fuel has units of Joules/kilogram. What is the approximate ratio of nuclear versus chemical energy density?  
 A) 1      B)  $10^3$       C)  $10^6$       D)  $10^9$       E)  $10^{12}$
29. An amusement park ride called "The Rotor" has people standing in a vertical cylinder, in this case 6 m in diameter, which rotates and presses them against the wall with sufficient force that the floor can then drop without them sliding down the wall. Shown here is the magnitude of accelerometer data from a device carried in a pocket by a rider. Assuming the high plateau averages  $27.7 \text{ m/s}^2$ , what is the peak centripetal acceleration? (Consider the spikes noise caused by movement of the rider.)

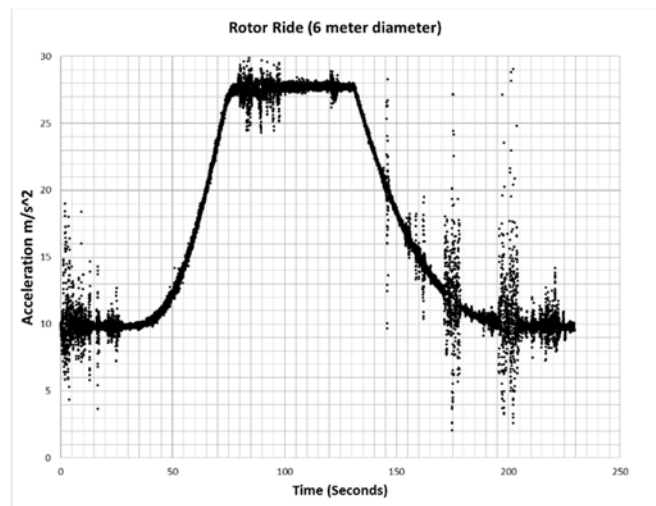

- A) 0      B)  $10 \text{ m/s}^2$       C)  $20 \text{ m/s}^2$       D)  $26 \text{ m/s}^2$       E)  $28 \text{ m/s}^2$

30. You drop a rock off a bridge into the river below and hear the splash 2.5 s later. How far above the river is the bridge?  
A) 25 m      B) 27 m      C) 29 m      **(D) 31 m**      E) 33 m

31. Any nucleus that emits an alpha particle or beta particle  
A) always becomes a nucleus of a different element  
B) may become a nucleus of a different element  
C) becomes a different isotope of the same element  
D) increases its mass number  
E) increases its mass

32. A child, starting from rest at the top of a 3.00-m tall slide, has a speed of 2.52 m/s at the bottom of the slide. What percent of the mechanical energy of the child-Earth system at the top of the slide remains when the child reaches the bottom of the slide?  
A) 8.4%  
B) 10.6%  
C) 32.5%  
D) 46.0%  
E) It cannot be determined without knowing the mass of the child.

33. Two identical uniform sticks have small holes drilled in them. The sticks are marked with equally spaced lines as shown. Each stick is suspended from a pin through the hole and is free to rotate about the pin. Both sticks are displaced a small angle from the vertical and released. What is the ratio of the period of pendulum one to the period of pendulum two?  
A) 1:1      B) 2:3      C) 4:3      D) 10:9      E) 16:9

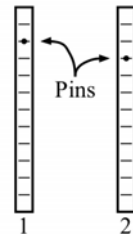

34. A projectile will be launched from a 2.00-m tall platform and must hit a target at a horizontal distance of 25.0 m away on an identical 2.00-m tall platform. What is the slowest speed at which the projectile can be launched?  
A) 10.2 m/s      B) 12.5 m/s      C) 15.8 m/s      D) 17.7 m/s      E) 21.0 m/s
35. A motorcycle has a total mass of 150 kg. Each wheel has a mass of 10 kg and a radius of 30 cm. As the motorcycle is moving, what is the ratio of the rotational kinetic energy of the wheels to the total translational kinetic energy of the motorcycle? Assume the wheels are uniform disks and roll without slipping.  
A) 0.033:1      B) 0.067:1      C) 0.33:1      D) 0.67:1      E) 3.3:1
36. A spring loaded projectile launcher launches a plastic ball horizontally with a speed of 4.0 m/s. If the spring were compressed twice as far, the ball's launch speed would be  
A) 1.0 m/s      B) 2.0 m/s      C) 4.0 m/s      D) 8.0 m/s      E) 16 m/s
37. You are given three identical resistors, each of resistance  $R$ . Each resistor can sustain a maximum power of  $P$ . Two of the resistors are connected in series, and a third is connected in parallel with these two. What is the maximum power this network can sustain?  
A)  $\frac{2P}{3}$       B)  $\frac{3P}{2}$       C)  $2P$       D)  $3P$       E)  $6P$



38. A man of mass  $m$ , gets off a boat by leaping to the left in an exactly horizontal direction. Both the man and the boat were initially stationary. Immediately after the leap, the boat of mass  $M$ , is observed to be moving to the right at speed  $v$ . What is the increase of the kinetic energy in the man-boat system? (Neglect the resistive force of the water)
- A)  $\frac{1}{2}Mv^2$       B)  $\frac{1}{2}mv^2$       C)  $\frac{1}{2}(M + m)v^2$       D)  $\frac{1}{2}(M + \frac{M^2}{m})v^2$       E)  $\frac{1}{2}\frac{Mm}{(M+m)}v^2$
39. A monatomic ideal gas undergoes an adiabatic expansion. Which of the following statements is true about the gas?
- A) The final temperature of the gas is less than the initial temperature of the gas.  
B) Heat enters the gas from the surroundings during the process.  
C) The final pressure of the gas is greater than the initial pressure of the gas.  
D) Work is done on the gas from the surroundings during the process.  
E) The internal energy of the gas remains unchanged during the process.
40. What temperature exists inside a solar collector (effective collection area of  $15 \text{ m}^2$ ) on a bright sunny day when the outside temperature is  $+20^\circ\text{C}$ ? Assume that the collector is thermally insulated, that the Sun radiates the collector with a power per unit area of  $600 \text{ W/m}^2$ , and that the collector acts as a perfect blackbody.
- A)  $73^\circ\text{C}$       B)  $93^\circ\text{C}$       C)  $107^\circ\text{C}$       D)  $131^\circ\text{C}$       E)  $154^\circ\text{C}$

**DIVISION 1  
STUDENTS**

**STOP HERE**

Your last answer should be for #40. Numbers 41-50 should remain blank for Division 1 students.

**DIVISION 2  
STUDENTS**

**CONTINUE**

Answer questions #41 through #50.

Treat  $g = 10.0 \frac{m}{s^2}$  for ALL questions.

41. A P-type semiconductor is doped to produce one of the following. What will it produce:  
A) both holes and electrons  
B) positive electrons  
C) negative electrons  
D) holes  
E) positive protons
42. A radioactive sample of gas has a half-life of 100 seconds. If there are initially 10000 of these gas molecules in a closed container, approximately how many of the molecules remain after a time of 250 seconds elapses?  
A) 2500      B) 2190      C) 1770      D) 1560      E) 1250

**Questions 43 & 44 refer to the circuit shown below**

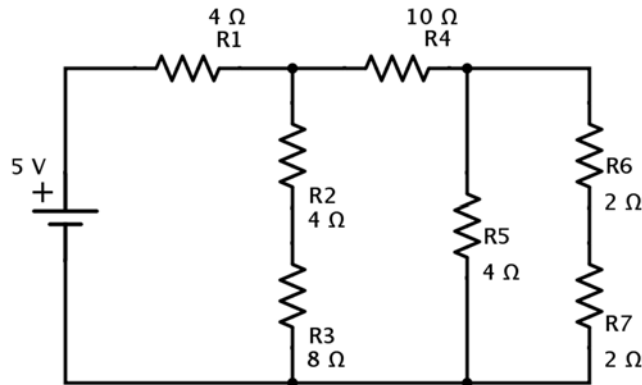

43. What is the voltage drop across  $R_5$ ?  
A) 0.250 V      B) 0.500 V      C) 1.00 V      D) 2.00 V      E) 3.00 V
44. What is the current in  $R_3$ ?  
A) 0.125 A      B) 0.250 A      C) 0.500 A      D) 0.750 A      E) 1.00 A

45. In the 1990s, the space shuttle flew two separate tethered satellite experiments. One purpose was to generate power via the induced voltage in a 20 km long tether moving perpendicular to the Earth's 0.5 Gauss magnetic field lines at roughly 8 km/s. What is the theoretical voltage across the tether to the nearest order of magnitude?
- A) 10 Volts  
 B) 100 Volts  
 C) 1,000 Volts  
 D) 10,000 Volts  
 E) 100,000 Volts

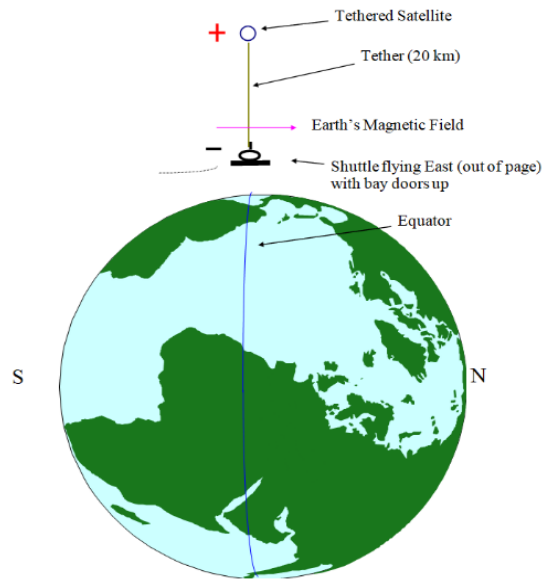

46. An engine absorbs heat at a temperature of  $727^{\circ}\text{C}$  and exhausts heat at a temperature of  $527^{\circ}\text{C}$ . If the engine operates at maximum possible efficiency, for 2000 J of heat input, the amount of work the engine performs is most nearly
- A) 400 J  
 B) 1450 J  
 C) 1600 J  
 D) 2000 J  
 E) 2760 J
47. In an ideal LC circuit, what is the time difference between all of the energy in the circuit being stored in the inductor and all of the energy being stored in the capacitor?
- A) No time difference  
 B) One-eighth of a period of oscillation  
 C) One-quarter of a period of oscillation  
 D) One-half of a period of oscillation  
 E) After one full period of oscillation has passed
48. Two identical metal spheres are hung from a common point by 30-cm long, nonconducting threads of negligible mass. The spheres each have a mass of 0.20 g and are given identical charges. It is found that due to the electrostatic repulsion force, the angle between the threads is  $20^{\circ}$ . How much charge was placed on each sphere?
- A) 11 nC  
 B) 16 nC  
 C) 21 nC  
 D) 26 nC  
 E) 31 nC

49. A collimated laser beam emerging from a commercial He-Ne laser has a diameter of 1.0 mm. Two convex lenses are used to convert this beam to a well-collimated beam with 10.0 mm diameter. The first lens has a focal length of 1.5 cm and is to be mounted at the output of the laser. What is the focal length,  $f$ , of the second lens and how far from the first lens should it be placed?

	<u><math>f</math> (cm)</u>	<u>Distance (cm)</u>
A)	4.5	6
B)	10	10
C)	10	11.5
D)	15	15
E)	15	16.5

50. A free electron (rest mass:  $m_e = 0.5 \frac{\text{MeV}}{c^2}$ ) has a total energy of 1.5 MeV. Its momentum,  $p$ , in terms of  $\frac{\text{MeV}}{c}$  is about
- A) 0.86      B) 1.0      C) 1.4      D) 1.5      E) 2.0

**IMPORTANT: All Division 2 students STOP HERE.**  
**Your last answer should be for #50.**